

Sunport Power Solar PV Modules

Installation and User Manual

This manual applies to Solar Photovoltaic Modules (hereafter referred to as “Modules”) manufactured by Jiangsu Sunport Power Corp., Ltd. (hereafter referred to as “Sunport”). Professional skills and knowledge are required for the installation. Only qualified installers after proper training can assume this job. Installers should follow all safety precautions described in this manual as well as local codes when performing installation and maintenance.

1. INTRODUCTION

Thank you for choosing Sunport as your PV module provider. You must read carefully and be familiar with this manual before handling, installing, and/or maintaining. This manual contains important information such as safety, installation, maintenance of modules, and other relevant information.

This manual is not in a form of any types of warranty document, expressed or implied. It does not stipulate compensation scheme of any loss, damage or other expenses caused by or generated during module installation, operation or maintenance. Sunport assumes no responsibility for any infringement of patents or other rights of third parties, which may result from using Sunport modules. Sunport reserves the right to make changes to its products or this manual without prior notice.

Sunport is not liable for any damages caused by inappropriate installation, use, or maintenance of Sunport modules, including without limitation damages, losses, and expenses caused by non-observance of the instructions of this manual or caused by or in connection with products of other manufacturers.

Failure to comply with the requirements listed in this manual will invalidate the Limited Warranty for modules as provided by Sunport at the same time of sales to the direct customers. Additional recommendations are provided to enhance safety practices and performance results. Please provide a copy of this manual to the PV system owner for their reference, and inform them all relevant aspects of safety, operation and maintenance.

This Installation and User Manual is available in different languages. In cases of discrepancy between versions, the Chinese language version shall prevail.

2. CODES AND REGULATIONS

The mechanical and electrical installation of PV systems should be performed in accordance with all applicable codes, including electrical codes, building codes, and electric utility interconnect



requirements. Such requirements may vary for mounting location. Requirements may also vary with system voltage, and for DC or AC application. Contact local authorities for detailed governing regulations, acquire confirmation and relevant permission.

3. MODULE INFORMATION

3.1 Encapsulation structure drawing

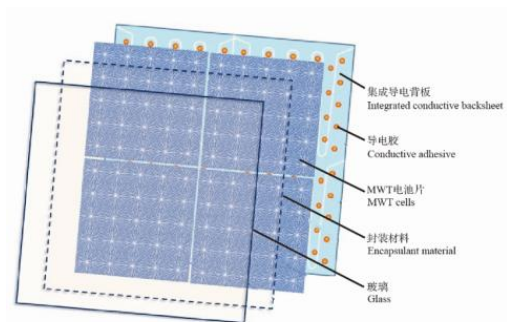

prevent them from falling over.

3.2 Module drawing

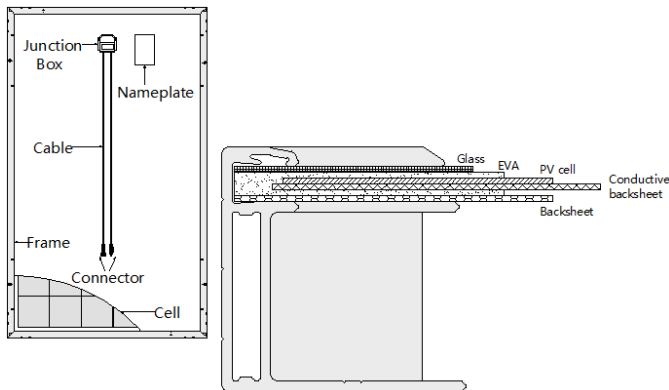

3.3 Nameplate

The nameplate describes the product type, peak power, the maximum power current, the maximum power voltage, open circuit voltage, short circuit current, the maximum system voltage and certification marks and etc. All of above are measured under standard test conditions.

4. SAFETY

Sunport's modules are designed to meet with the requirements of IEC 61215 and IEC 61730. The application class is A, meaning the modules can be used in system of 50Vdc or 235W or higher, to which the general public may have access. Sunport's modules also qualified for Safety Class II.

4.1 Transportation & storage safety

Do not open the original package during transportation and storage until they are ready to be installed. Protect it against damage during transportation. Secure the pallets from falling over. Do not exceed the maximum stack height limit when stacking as indicated by the symbols outside the package. The package shall be stored in a cool and dry location until the modules are ready to be unpackaged. The modules shall be handled at the frame. Never use the junction box or cables as a grip. Do not exert mechanical stress on the cables. Never step on modules or drop or place heavy objects on them. Be cautious when setting the modules down onto a surface, especially on the corner of the modules.

4.2 Operating safety

When unpacking the modules from the original package, first remove the pallet lid (after removing securing straps, if provided). Remove one module at a time. You may need to secure the remaining modules in the original packaging and

2020.09 F/1

Check modules for damage due to transportation before they are installed. Do not install damaged modules. Contact with us if you need to make claim of the defective products.

Do not attempt to remove any part from the modules; do not apply paint to or stick labels on the module surface; do not scratch on module back sheet to avoid any damage. Do not drill holes on the frame. This may compromise the frame strength and cause corrosion of the frame; do not attempt to disassemble or modify the modules for your safety. This may have negative effect on the module quality and safety, even irreversible damage. Additionally, all the warranty will be not available.

4.3 Electrical safety

In case that no load or external circuit being connected, photovoltaic modules can produce DC electricity when exposed to light and therefore can produce an electrical shock or burn. DC voltage of 30 Volts or higher is potentially lethal. Please use insulated tools and rubber gloves when working with modules in sunlight.

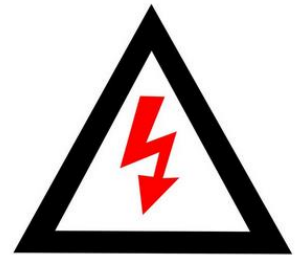

Modules have no on/off switch. Modules can be rendered inoperative only by removing them from sunlight area, or by fully covering their front surface with cloth, cardboard, or other completely opaque material, or flipping Modules, and placing the front side of Modules onto a smooth, flat surface.

In order to avoid arcs and electrical shock, please do not disconnect electrical connections under load. Faulty connections can also result in arcs and electrical shock. So please keep connectors dry and clean, and ensure that they are in proper working condition. Never insert any other metal objects into the connector, or modify them in any way in order to secure an electrical connection.

Do not touch or handle modules with broken glass, separated frames or damaged back sheet unless the modules are disconnected in advance and you are wearing proper PPE. Avoid handling modules when they are wet unless cleaning



the modules as directed in this manual. Never touch electrical connections that are wet, without PPE or insulated gloves.

Reflection from snow or water can increase sunlight and therefore increase current and power. In addition, low environmental temperature can also substantially increase voltage and power.

4.4 Fire safety

Consult your local authority for laws and codes; follow requirements for building or structural fire safety. Sunport's modules have been listed as Class C according to IEC 61730-2 standard. Use



appropriate components such as fuses, circuit breakers, grounding connectors, and so on as regulated by local authority.

Roof constructions and installations may affect the fire safety of building, it has to be covered by fire-proof material with appropriate class, and make sure there is adequate ventilation between back sheet and installation side. In order to maintain the fire class rating, the distance between the modules frame surface and the roof surface shall be at least 100mm; modules are electrical generating devices that may affect the fire safety of a building.

Electric arc may happen when module working due to the wrong installation method or defective module part. Please keep the combustible liquid, gas and dangerous cargo away from the module. You must stop using the module if there is exposed combustible gas nearby.

In the event of a fire, modules may continue to produce a dangerous DC voltage, even if they have been disconnected from the inverter, have been partly or entirely destroyed, or the system wiring has been compromised or destroyed. In the event of fire, inform the fire crew about the particular hazards from the PV system, and stay away from the PV system during and after a fire until the necessary steps have been taken to make the PV system safe.

5.INSTALLATION

5.1 Installation condition

Sunport's modules must be mounted on buildings or other structures suitable for modules installation (e.g. ground. 2020.09 F/1

rooftop). Modules must not be mounted on moving vehicles of any kind; Modules can be installed in seaside with a distance of 50m to 500m from sea. Corrosion may happen to joints between frame and supporter, or and grounding; Must use stainless steel or aluminum metal to directly contact modules in seaside and do antiseptic treatment on joints to prevent corrosion; Modules must not be installed, nor operated in area with strong corrosive matter, such as salt, salt mist, salt-water, active chemical vapors, acid rain, any other type of corrosive matter. In addition, Modules must not be sit in locations where hail, snow, sand, smoke, air pollution, soot, etc. are excessive, this could affect the safety and/or performance of the modules.

The recommended ambient temperature should be within -20°C (-4°F) to 46°C (115°F), the temperature limits are defined as the monthly average lowest and highest of the installation site; The limit operating temperature should be -40°C (-40°F) and 85°C (185°F); Do not apply mirrored, magnifiers or other concentrate light onto the modules.

Sunport recommends installing the modules with a tilt angle of at least 10 degrees, making it easier for dust to be washed off by rain and reduce the time of cleaning; In addition, this will help to drain the water out directly from the surface, avoid watermarks from trapping water on the glass surface and affect the appearance and performance of modules.

Partial or complete shading of a module or modules can significantly reduce system performance. Sunport recommends installing modules in the place without shade throughout the year to increase the amount of energy produced by the modules; Lightning protection is recommended for PV systems that are to be installed in locations with high probability of lightning strikes.

In the northern hemisphere, modules should typically face south, and in the southern hemisphere, modules should typically face north; For detailed information on the best installation angle, please refer to standard solar photovoltaic installation guides or consult a reputable solar installer or systems integrator.

5.2 Mechanical installation

Ensure that the installation method and supporting system of modules is strong enough to make the modules to be able to withstand all the pre-established load conditions. The installer

must provide the guarantee. The installation supporting system must be tested by the third-party organization with the analysis ability of Static Mechanical, according to the local national or international standards such as DIN1055 or equivalent standards.

The modules mounting structure must be made of durable, corrosion-resistant and UV-resistant material; Modules must be securely attached to the mounting structure; In regions with heavy snowfall in winter, select higher mounting system. So that the lowest edge of the modules will not be covered by snow for long time. In addition, ensure that the lowest portion of the modules is placed high enough so that it will not be shaded by plants or trees, or damaged by flying sand; Because of thermal and expansion of the module frames, must ensure that the minimum distance between neighboring frames is 10mm.

5.2.1 Modules installed with mounting holes

To maximize mounting longevity, Sunport strongly recommends the use of corrosion proof (stainless steel) attachment hardware. Secure the module with an M8 bolt and a flat washer, spring washer and nut. Standard specification of flat washer: Washer ISO 7093-1-8. Standard specification of spring washer: Washer DIN 127-8. Each module must be securely fastened at a minimum of four points on two opposite sides. Modules should be bolted to support structures through mounting holes located in the frame's back flanges. Bolt torque range: 16N.m to 20N.m.

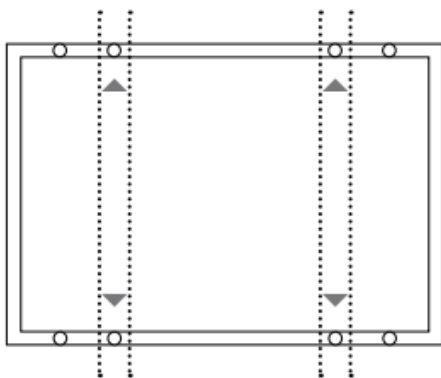

The long side frame is installed with 4 bolt mounting holes on the outside or inside. Mounting rails run perpendicularly to the long side frame.

Maximum Load (1.5 times safety factor)	Uplift load \leq 1600 Pa Downforce load \leq 3600 Pa
---	---

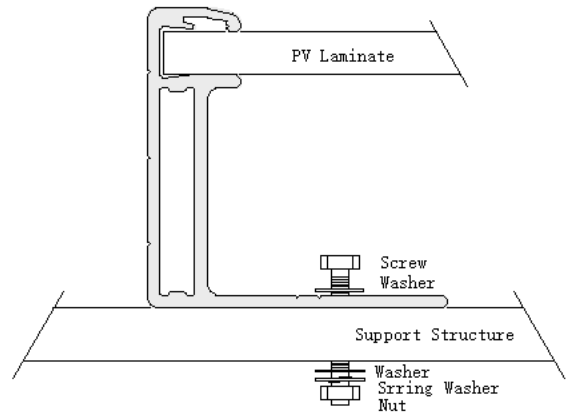

5.2.2 Modules installed with clamp

Each module must be securely fastened at a minimum of four points on two opposite sides. Modules should be bolted to the support with the clamp. Bolt torque range: 18N.m to 24N.m. at least M6 fixing bolt. The clamp must overlap the module frame by at least 7mm but no more than 10mm.

The clamps should be positioned symmetrically. The clamps should be positioned according to the authorized position ranges defined in the table.

Method A: Use four clamps on the long side. Mounting rails run perpendicularly to the long side frame.

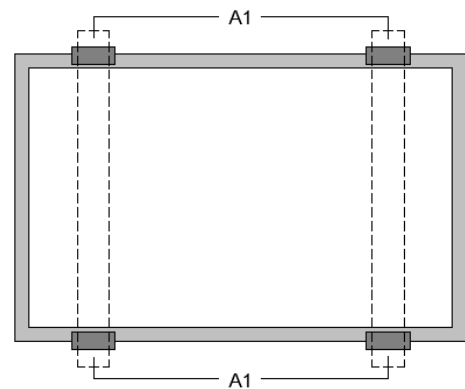

Module Type	SPPXXXP/M60、SPPXXXP/MH6、SPPXXXD/N60、SPPXXXD/NH6、SPPXXXP/M60H、SPPXXXP/MH6H、SPPXXXD/N60H、SPPXXXD/NH6H、SPPXXXD/NHEH、 <i>SPPXXXD/NHFH</i>	
Module Height	30mm	35mm
A1 range (mm)	860 - 1200	860 - 1300
Maximum Load:	Uplift load \leq 1600 Pa	

(1.5 times safety factor)	Downforce load ≤ 3600 Pa
Module Type	SPPXXXP/M72、SPPXXXP/MH7、 SPPXXXD/N72、SPPXXXD/NH7、 SPPXXXP/M72H、SPPXXXP/MH7H、 SPPXXXD/N72H、SPPXXXD/NH7H、 SPPXXXD/NHJH
Module Height	35mm 40mm
A1 range (mm)	1180 - 1360
Maximum Load: (1.5 times safety factor)	Uplift load ≤ 1600 Pa Downforce load ≤ 3600 Pa

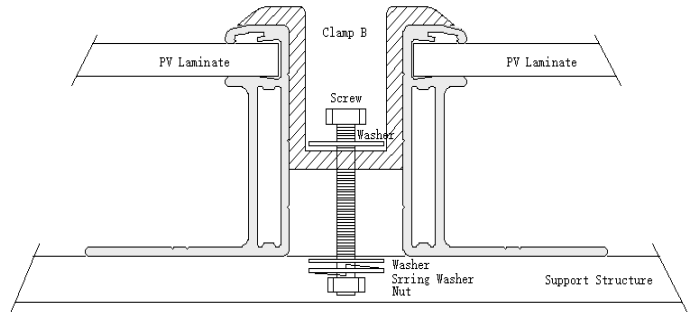

Clamp B between the modules

5.3 Electrical installation

The deviations always exist between the nominal value and test value in standard test condition of Rated electrical characteristics of module such as I_{sc} , V_{oc} and P_{max} , Standard Test Conditions: 1000 W/m^2 Irradiance, 25°C Cell Temperature and 1.5 Air Mass, normally, the value of current and voltage generated from Modules will be probably higher than values under standard test condition. When determining module voltage ratings, conductor current ratings, fuse sizes, and size of controls connected to the PV output, on the basis of highest local temperature, combine with temperature coefficient of current in manual, I_{SC} can be calculated by multiplying by the coefficient of 1.25; On the basis of lowest local temperature, combine with temperature coefficient of voltage in manual, V_{oc} can be calculated. When modules are in series, voltage to be added up; when modules are in parallel, current to be added up. PV modules with different electrical properties can't be connected in series, different electrical components of modules may cause mismatch of electrical connection, make sure to install them in accordance with manual provided by manufacturer.

5.3.1 Connection type

The maximum number of modules that can be connected in a series string must be calculated in according with applicable regulations in such a way that the specified maximum system voltage (According to IEC61730 tests and appraisal, the maximum system voltage is 1000Vdc or 1500Vdc depending on the series and model.) of the modules and all other electrical DC components will not be exceeded in open circuit operation at the lowest temperature expected at the PV system location. Correction factor for the open-circuit voltage can be calculated based on the following formula: $V_{oc} = 1 - \beta V_{oc} \times (25 - T)$. T is the lowest expected ambient temperature at the system location. β (%/°C) is the temperature coefficient of the selected module V_{oc} (Refer to corresponding datasheet).

Method B: Use four clamps on the short side. Mounting rails run parallel to the long side frame.

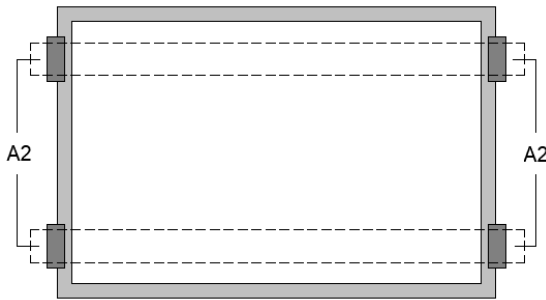

Module Type	SPPXXXP/M60、SPPXXXP/MH6、 SPPXXXD/N60、SPPXXXD/NH6、 SPPXXXP/M60H、SPPXXXP/MH6H、 SPPXXXD/N60H、SPPXXXD/NH6H
Module Height	30mm 35mm
A2 range (mm)	540 - 710
Maximum Load: (1.5 times safety factor)	Uplift load ≤ 1600 Pa Downforce load ≤ 2400 Pa

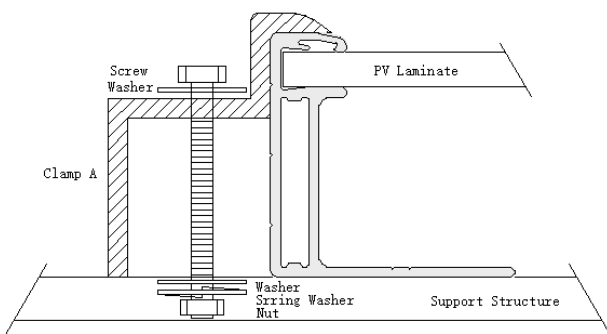

Clamp A at the module edge

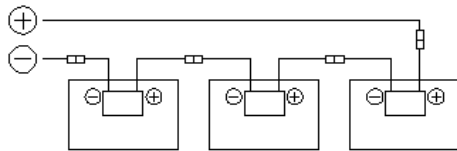

Series wiring

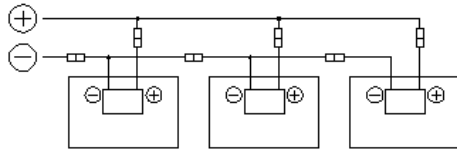

Parallel wiring

An appropriately rated over-current protection device must be used when the reverse current could exceed the value of the maximum fuse rating of the modules. An over-current protection device is required for each series string if more than two series strings are connected in parallel.

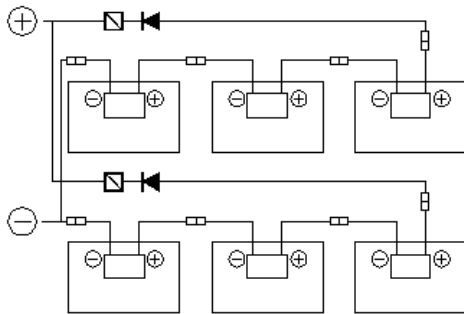

Series wiring and Parallel wiring

Over-current protection devices
 Diodes
 Connector

These junction boxes have been designed to be easily interconnected in series for their good connected cable and the connector with IP67 protection grade. Each modules has two single conductor wires, one positive and one negative, which are pre-wired inside the junction box. The connectors at the opposite end of these wires allow easy series connection of Sunport's modules by firmly inserting the positive connector of a module into the negative connector of a Sunport module until the connector is fully seated.

Modules connected in a parallel string are not recommended since the large current in the modules and the cable wires, which will result in power loss.

5.3.2 Cables

Use field wiring with suitable cross-sectional areas that are approved for use at the maximum short-circuit current of the module. Sunport recommends installers use only sunlight resistant cables qualified for direct current (DC) wiring in PV 2020.09 F/1

systems. (Satisfy the code TÜV 2 PFG 1169、4mm²、Temperature range:-40°C to +90°C) ; Cables should be fixed to the mounting structure in such a way that mechanical damage of the cable and/or the modules is avoided; Do not apply stress to the cables; For fixing, use appropriate means, such as sunlight resistant cable ties and/or wire management clips specifically designed to attach to the modules frame. While the cables are sunlight resistant and waterproof, where possible, avoid direct sunlight exposure and water immersion of the cables.

5.3.3 Connectors

Keep connectors dry and clean, and ensure that connector caps are hand tight before connecting the modules. Do not attempt to make an electrical connection with wet, soiled, or otherwise faulty connectors. Avoid sunlight exposure and water immersion of the connectors. Avoid allowing connectors to rest on the ground; Faulty connections can result in arcs and electrical shock. Check that all electrical connections are securely fastened. Make sure that all locking connectors are fully engaged and locked.

5.3.4 Bypass diodes

The junction boxes used with Sunport's modules contain bypass diodes wired in parallel with the PV cell strings. In the case of partial hot spot, the diodes bypass the current generated by the cells with hot spot, thereby limiting modules heating and performance losses. Bypass diodes are not over-current protection devices. In the event of a known or suspected diode failure, installers or maintenance providers should contact Sunport. Never attempt to open the junction box by yourself.

5.4 Ground protection

Sunport's modules use an anodic oxidized aluminum frame to resist corrosion. So the frame of modules must be connected to the equipment grounding conductor to prevent thunder and static injury; The grounding device must fully contact with the inside of the aluminum alloy, and must penetrate the surface of the frame oxidation film; Please do not drill any additional grounding hole on the frame of the modules; For optimal performance, Sunport recommend the DC cathode of the modules array is connected to ground. Failure to comply with this requirement may reduce the performance of the system. The grounding method must not result in direct contact of dissimilar metals with the aluminum frame of the modules that will result in galvanic corrosion. An addendum to UL



Standard 1703 《Flat Plate Photovoltaic Modules and Panels》 recommends metal combinations not exceed an electrochemical potential difference of 0.6 Volts. The frame rails have pre-drilled holes marked with a grounding sign. These holes should be used for grounding purposes and must not be used for mounting the modules.

5.4.1 Grounding by using grounded clamp

There are 8 grounding holes with 4.3mm diameter on the frame from the backside of the Modules. The user may select one of them according to the actual situation. The grounding between modules must be approved by qualified electrician. And the grounding device must be produced by qualified electrical manufacture. The recommended twist torque value is 2.3 N.m. A copper core in size of 12 AWG can be used as grounding clamp. The copper wire should not be compressed during the installation.

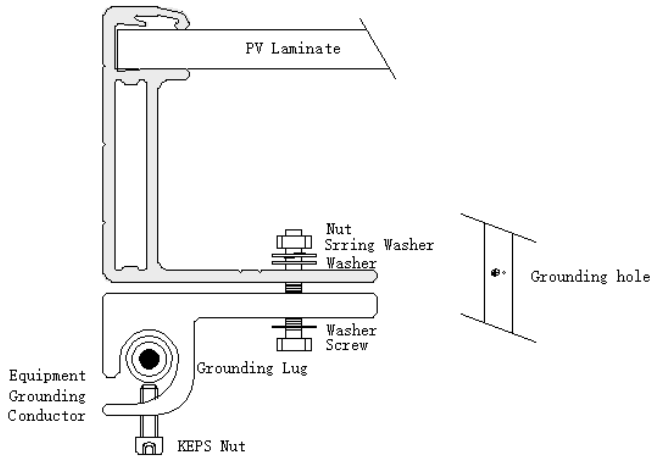

5.4.2 Grounding by using grounded bracket

Sunport’s modules can be grounded by connecting with the grounding bracket. The proper grounding must be qualified and follow the installation manual from the provider.

5.4.3 Additional third-party grounding devices

Sunport’s modules can be grounded by using third party grounding devices so long as they are certified for grounding modules and the devices are installed according to the manufacturer’s specified instructions.

6.MAINTENANCE AND REPAIR

Sunport recommends that PV systems shall be periodically inspected by the installer or qualified person.

6.1 Maintenance

Whether the glass is broken; Whether there is burning vestige
2020.09 F/1

on the backsheet; All cables and connector attachments are undamaged and properly secured; Mounting and grounding components are tightly secured with no corrosion.

6.2 Repair

In order to reduce the potential for electrical and thermal shock, Sunport recommends cleaning modules during early morning or late afternoon hours when solar radiation is low and the modules are cool, especially in regions with high temperatures.

When modules are working, there should not be environmental influence factors to cast shadows and cover part or even all of the modules, such as other modules, system support, bird drops and a lot of dust, clay or plant and so on, these may distinctly reduce the power output. Sunport advises that there should be no obstructed object over the modules surface at any time.

The cleaning frequency depends on the accumulated frequency of the fouling. In many instances the front surfaces of the modules will be cleaned with the rain, and we can decrease the cleaning frequency; Sunport’s modules may contain a hydrophobic anti-reflective coating on the glass surface to enhance power output and reduce dirt and dust buildup; In order to avoid module damage, do not clean PV modules with a power washer or pressure washer, it is recommended to wipe the glass surface with a wet sponge or soft cloth. Please do not clean the glass with a cleaning agent which contains acid or alkali; However, if removing snow is desired to enhance production, use a brush to gently remove snow; Do not try to remove frozen snow or ice from THE modules.

7.MODEL RANGE

The installation manual applicable module types are as follows. The module types are subject to changes without prior notice due to continuous product innovation, research and development. “XXX” shows the peak power of the module Label in increment of 5.

Module Type	Dimension(L×W×H)
	mm
SPPXXXP60、SPPXXXM60、 SPPXXXP60H、SPPXXXM60H	1640×992×30/35
SPPXXXPH6、SPPXXXMH6、	1650×992×30/35



SPPXXXPH6H、SPPXXXMH6H	
SPPXXXD60、SPPXXXN60、 SPPXXXD60H、SPPXXXN60H	1680×1016×30/35
SPPXXXDH6、SPPXXXNH6、 SPPXXXDH6H、SPPXXXNH6H	1690×1016×30/35
SPPXXXP72、SPPXXXM72、 SPPXXXP72H、SPPXXXM72H	1956×992×40/35
SPPXXXPH7、SPPXXXMH7、 SPPXXXPH7H、SPPXXXMH7H	1970×992×40/35
SPPXXXD72、SPPXXXN72、 SPPXXXD72H、SPPXXXN72H	2006×1016×40/35
SPPXXXDH7、SPPXXXNH7、 SPPXXXDH7H、SPPXXXNH7H	2020×1016×40/35
SPPXXXDHEH、SPPXXXNHEH	1772×1016×30/35
SPPXXXDHJH、SPPXXXNHJH	2005×1105×35
<i>SPPXXXDHFH、SPPXXXNHFH</i>	<i>1855×1015×30</i>

8.CONTACT

Jiangsu Sunport Power Corp., Ltd.

Addr.: NO.20, Xishi Road, Xinwu District, Wuxi City, Jiangsu
Province, 214028, P.R.China

E-mail: info@sunportpower.com

www.sunportpower.com